



# **XLINE PLUS**

An architectural linear lighting system

# XLINE PLUS

Aesthetic and Minimalist

Originate from last generation, Xline™ plus is aesthetic and minimalist, easier for installations and newly developed the surface and track mounted besides the pendant. It's flexible and seamless continuous connection to build creative and innovative lighting system.

Distinctively rectangular aluminum luminaire housing from extruded aluminum profile; No visible screws; Indirect output reflected from the ceiling provide a softer and ambient illumination. The vacuum aluminum plating faceted louver with lens design minimized the glare. Suitable for VDUs workplace light according to EN 12464-1 (UGR 19, UGR 22); Available in 1167mm and 2330mm of length, with DALI, 0-10V or ON/OFF dimming control. Various lighting distributions meet the requirement of generation lighting, asymmetric distribution for shelves and wallwasher, bi-symmetric distribution for aisle lighting.

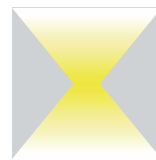
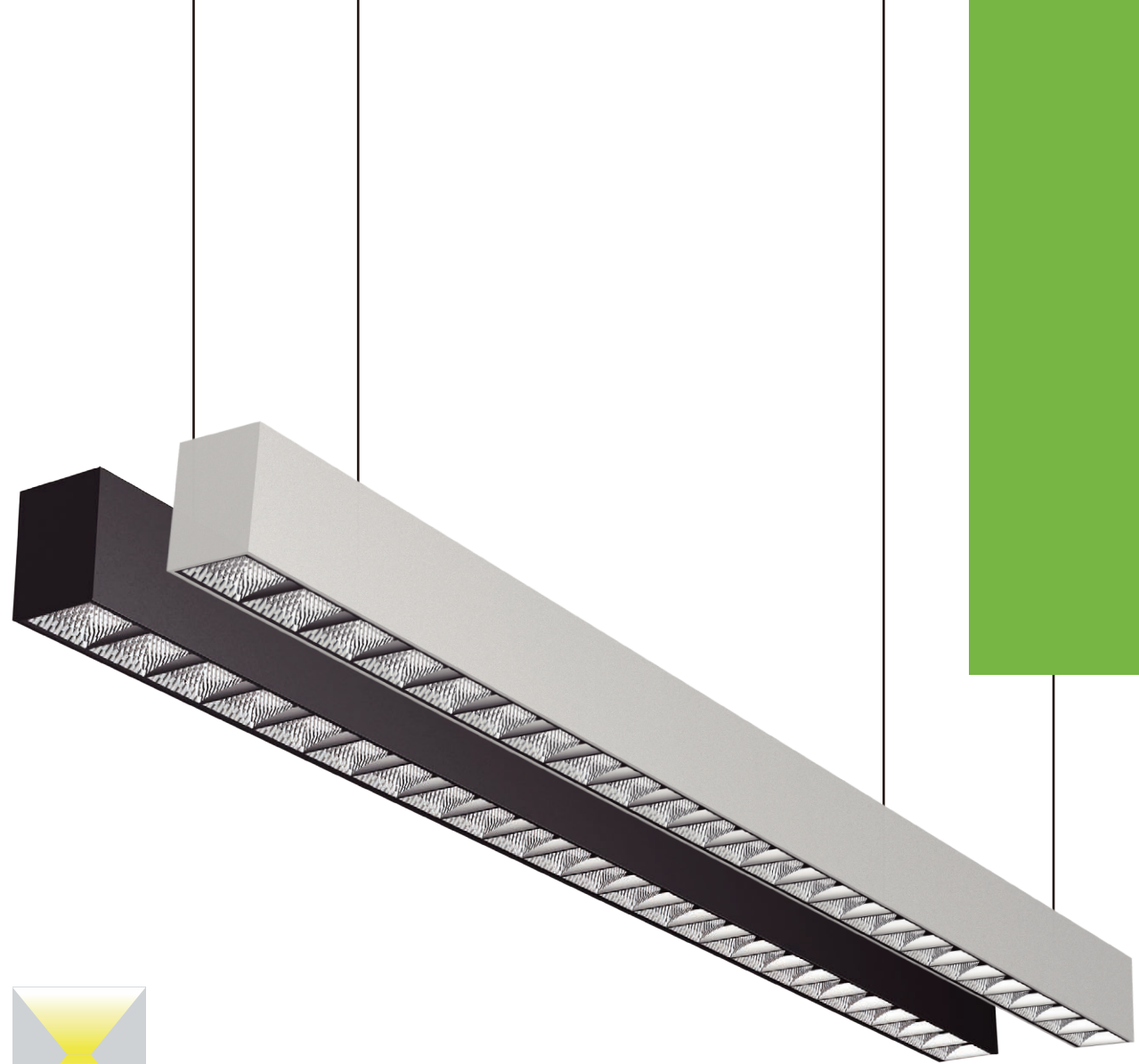

1-10V

DALI

ON/OFF

110lm/W

~~FLICKER~~

SAMSUNG





## **APPLICATION**

Ideal for offices, lobbies, conference rooms, libraries, classrooms, shops, and many other applications



## INSTALLATION

Pendant, Surface, Track Mounted





## FEATURES

Seamless continuous  
Indirect and direct lighting  
Low UGR of 19, or 22  
Up to 110lm/W system efficacy  
Visual comfort

## OPTICS DESIGN

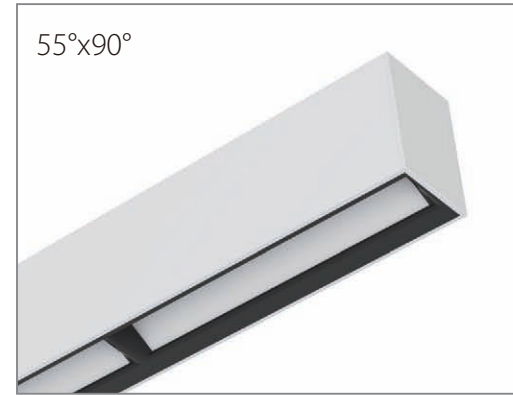
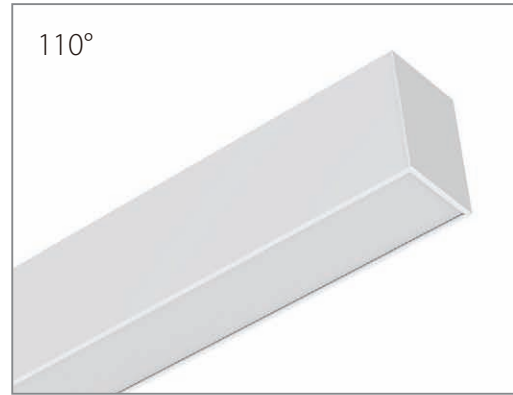
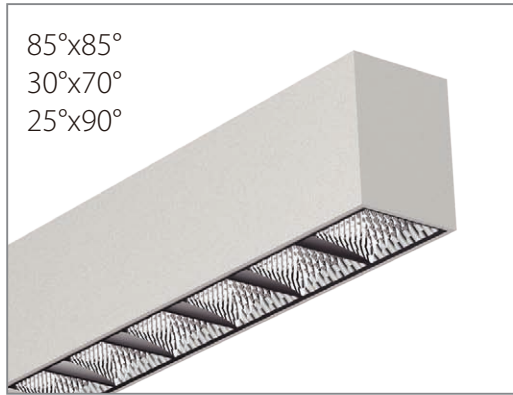

## DISTRIBUTIONS & INDIRECT LIGHT

Aisle Lighting: 30°x70°

General Lighting: 85°x85°, 110°

Asymmetric Vertical Lighting (by request): 25°x90°, 55°x90°



Up and down light percentage option

↑ 0% 10% 30% 50%



↓ 100% 90% 70% 50%

## SEAMLESS CONTINUOUS DESIGN

Various connectors are perfectly fitted together which allows for a free assembly into light-line systems of different lengths, and different patterns seamless.

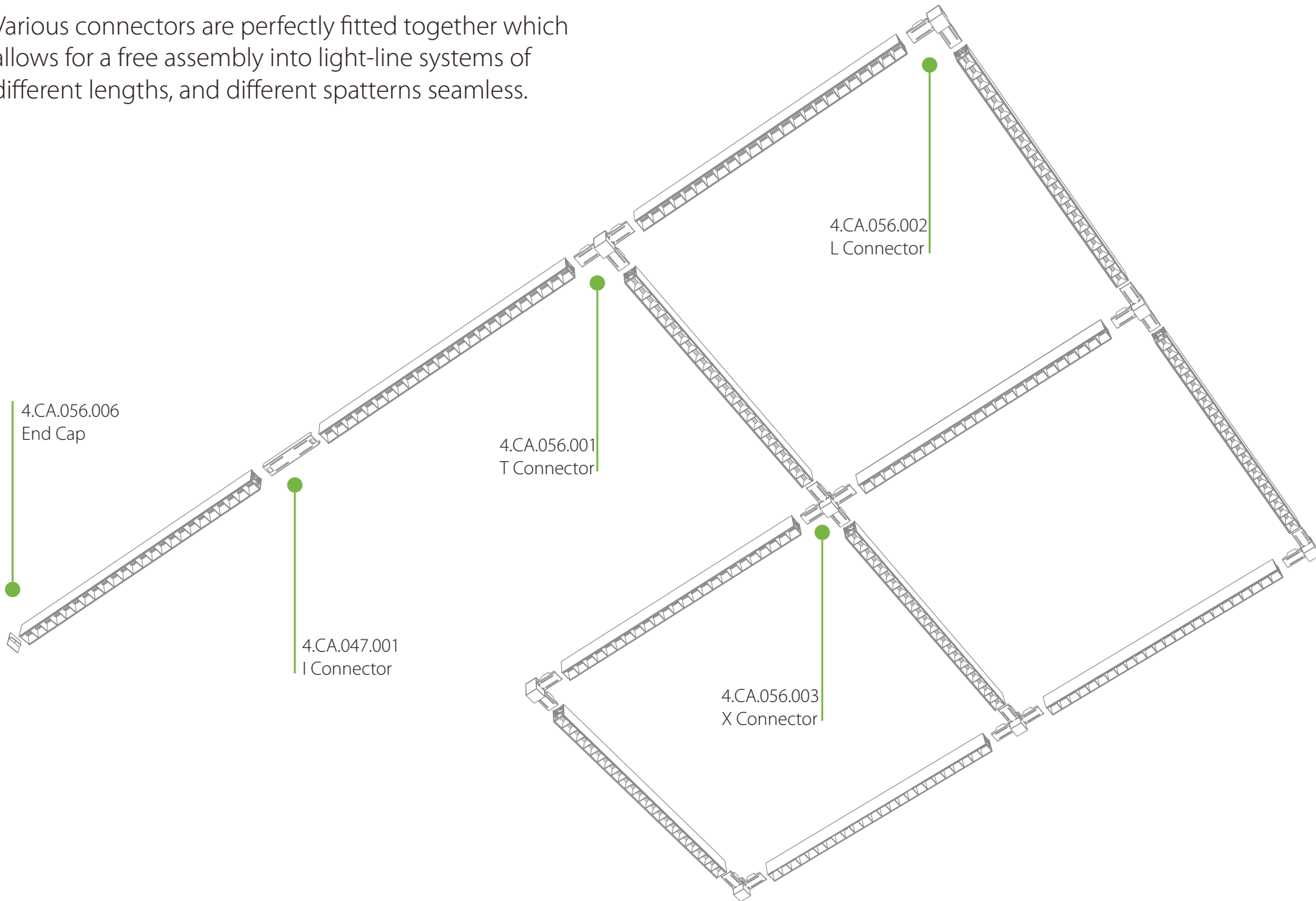

# INSTALLATIONS

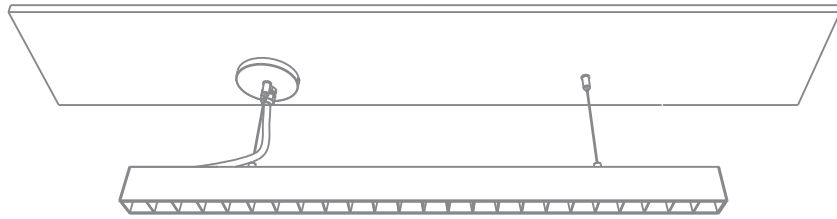

200cm length aircraft cable suspension has continuous adjustment in vertical and horizontal direction

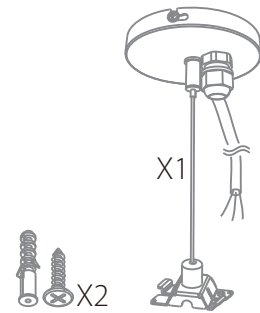

4.CA.056.004  
Pendant mounted kit 1

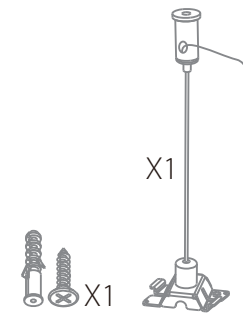

4.CA.056.005  
Pendant mounted kit 2

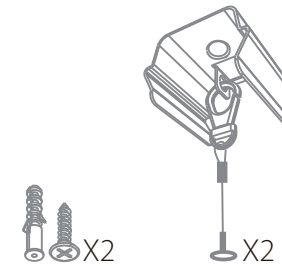

4.CA.056.007  
Surface mounted Kit

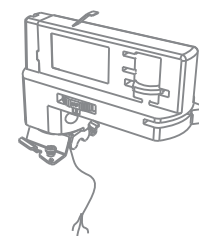
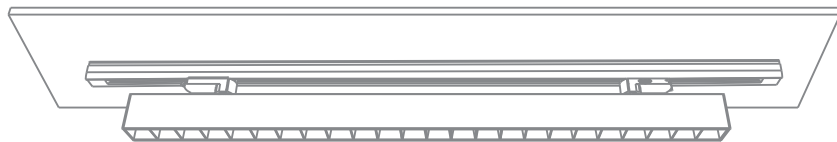

3F/GAC69  
Track mounted kit with cable

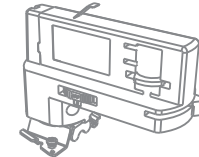

3F/GAC69  
Track mounted kit without cable



# DATA SHEET

|                    |   |                           |
|--------------------|---|---------------------------|
|                    | 1167mm  | 2330mm                    |
| Wattage - Lumen    | 27W 3000lm<br>45W 5000lm  | 45W 5000lm<br>90W 10000lm |
| System Efficacy    | 110lm/W   |                           |
| LED Brand          | Samsung LED   |                           |
| Beam Angle         | 30°x70°, 85°x85°, 110°; Asymmetric(by request) 25°x90°, 55°x90° |                           |
| CRI                | 80, 90 by request   |                           |
| SDCM               | ≤5 MacAdam  |                           |
| CCT                | 3000K, 4000K, 5000K   |                           |
| DIMMING            | Flicker Free: DALI, 0-10V, ON/OFF                               |                           |
| Input Voltage      | 200-240V  |                           |
| Power Factor       | 0.95  |                           |
| IP                 | IP20  |                           |
| Luminarie Material | Extrusion Aluminum  |                           |



# SELECTED ORDER NUMBER

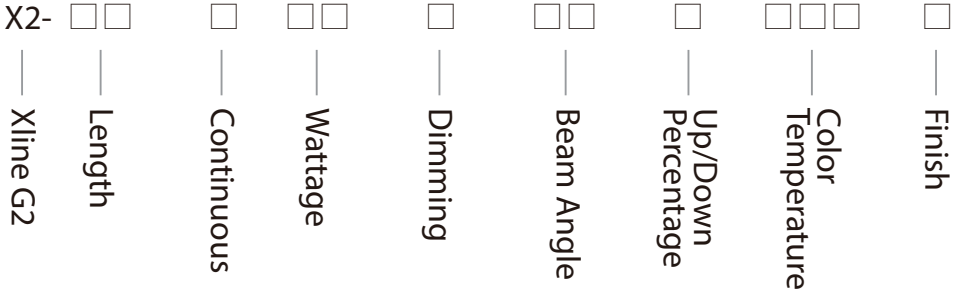

|   |   |  |  |
|---|---|--|--|
| <p>Length</p> <p>12 - 1167mm</p> <p>24 - 2330mm</p>   | <p>Continuous</p> <p>C - Continuous<sup>1</sup></p> <p>N - Non Continuous<sup>2</sup></p>                     | <p>Wattage</p> <p>27 - 27W, 3000lm</p> <p>45 - 45W, 5000lm</p> <p>90 - 90W, 10000lm</p>  | <p>Dimming</p> <p>0 - ON/OFF, Flicker Free 220-240V</p> <p>1 - DALI, Flicker Free 220-240V</p> <p>2 - 0-10V, Flicker Free 220-240V</p> |
| <p>Beam Angle</p> <p>B1 - 85°x85° Batwing</p> <p>B2 - 30°x70° Bi symmetry</p> <p>L1 - 110° Lambertian</p> <p>OB - Other beam by request</p> | <p>Up/Down Percentage</p> <p>0 - 0% : 100%</p> <p>1 - 10% : 90%</p> <p>3 - 30% : 70%</p> <p>5 - 50% : 50%</p> | <p>Color Temperature</p> <p>830 - 3000K Ra82</p> <p>840 - 4000K Ra82</p> <p>850 - 5000K Ra82</p> <p>857 - 5700K Ra82</p> <p>930 - 3000K Ra90</p> <p>940 - 4000K Ra90</p> <p>950 - 5000K Ra90</p> <p>957 - 5700K Ra90</p> | <p>Finish</p> <p>B - Black</p> <p>W - White</p> <p>O - Other finish by request</p>   |

**NOTE:**

- 1, Continuous: without end caps, but include continuous cables and terminals
- 2, Non Continuous: with end caps, but without continuous cables and terminals
- 3. Mounted accessories and continuous connector order seperately.



Professional  
Unique  
Comfortable  
LED LIGHTING

Kinglumi has set its social networks on Facebook, LinkedIn, Youtube and Twitter, new products and company news will be posted on all these platform. It would be a pleasure to meet you there, and you can “share” and “like” what you are interested in.



[www.facebook.com](http://www.facebook.com)



[www.linkedin.com](http://www.linkedin.com)



[www.youtube.com](http://www.youtube.com)



[www.twitter.com](http://www.twitter.com)

Add: Bldg 3, Nangang Third Industrial Zone, Tangtou, Shiyao Town, Bao'an District, Shenzhen  
City, China 518108  
Tel: 0086-755-29516789 36690866  
E-mail: [sales@kinglumi.com](mailto:sales@kinglumi.com)  
Fax: 0086-755-29516759  
Http: [//www.kinglumi.com](http://www.kinglumi.com)

Working hours: From Monday to Friday 8:30 to 18:00